

## Step Motor Driver SMD73 (Vers. ≥ 1.3)

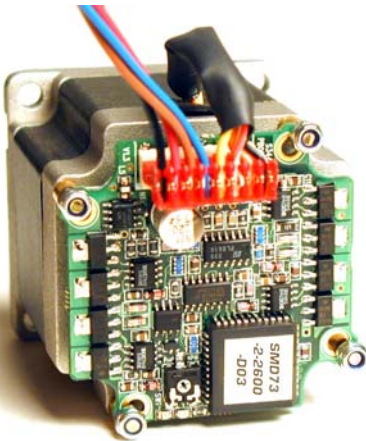

### Step resolution:

As standard, the SMD73 can be delivered with step resolutions of 1/1, 1/2, 1/4, 1/5 and 1/8 (200, 400, 800, 1000 and 1600 pulses/rev).

### Running current:

The default running current is 2.6 ARMS and standby current is 0.86 Amp. Changing 2 resistors, R5 and R6, (see next page), can alter the operating

current. Standby current will always be 1/3 of the running current. Other currents can be achieved by selecting other resistor values. However the two resistors must always have the same value. The table below gives typical values for running current and standby current for different resistor values. The current is measured RMS at 50 step/sec.

R5 and R6 (ohm)	Running Current RMS (mA)	Standby current RMS (mA)
150	250	80
270	500	170
390	750	250
560	1000	330
664	1250	420
820	1500	500
980	1750	580
1150	2000	660
1260	2250	750
1500 (default)	2600	860
1800	3000	1000

### Standby current:

Standby current is always 1/3 of running current (1:3). Different ratios from 1:1 and up to 1:31 can be specially programmed by JVL for orders of more than 100 units per shipment. JVL modifies the EPLD U1 and the user cannot do this.

### Minimum current

Note that the minimum current is dependent on winding inductance and resistance in the step motor. If e.g. a step motor with low inductance is used and the current of 0.10 Amp is

required, this cannot be accomplished because of a small time delay in the driver. (Min. current =  $\text{SupplyVoltage} \times 0.02 / \text{Phase Resistance}$ ).

For example, the Vexta PK245-01A has 3.3 ohm phase resistance. At 24V this results in a minimum current of 0.15 Amp.)

### Ordering code

SMD73-2-1000E03□

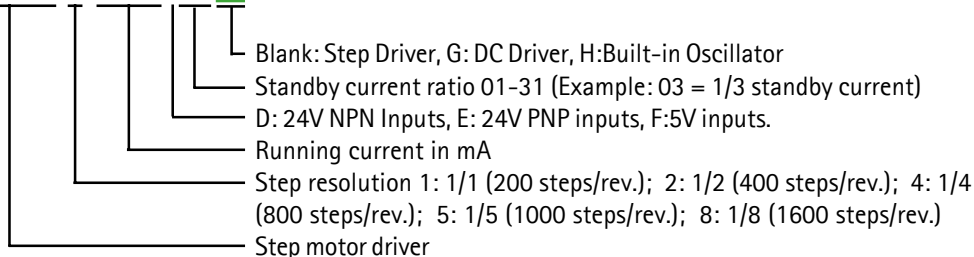



### Step and direction input:

The standard version of the Step Motor Driver SMD73 is intended for 24V NPN signals. By turning the PNP/NPN Switch anti-clockwise, the step and direction

inputs can be changed to 24V PNP. If 5V input is required, solder a jumper on Z1 (see next page), on the back of the PCB. The table below gives the "High"

and "Low" signal levels for NPN and PNP inputs. Placement of the resistors can be seen below on the circuit board illustration and the circuit diagram.

	"High signal" [Volt]	"Low signal" [Volt]	PNP/NPN selector	5V/24V selector Z1 (on rear side of print)
PNP	7,5-30VDC	0-7,5 VDC	Turn left (PNP)	Off
NPN (Default)	7,5-30VDC	0-7,5 VDC	Turn right (NPN)	Off
5V TTL/CMOS	2.5-30VDC	0-2.5VDC	Don't care	On

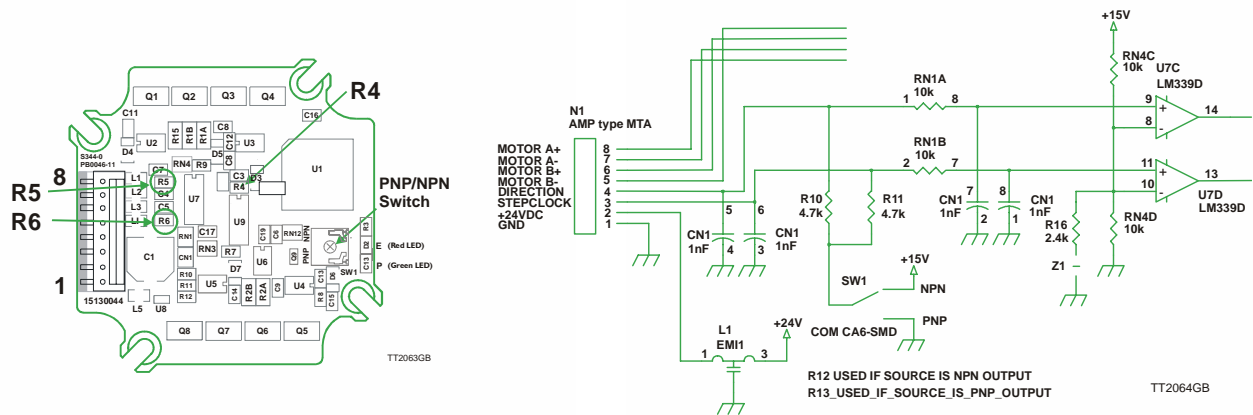

### DC driver

The SMD73 can also be used for controlling DC motors. The 2 inputs can for example be configured to select

direction, enable or low/high speed. Other configurations are possible. If one DC motor is controlled, the current

can be a maximum of 8 Amp. If 2 DC motors are to be controlled, the maximum current for each is 4 Amp.

Pin no. on SMD73 connector	Pin description SMD73	WG0104 * 4 pole connector	WG0108 * 8 pole connector	WG0114 Clk/dir with shield and power	WG0112 Motor cable with shield	MST001A-73 Motor with special clkdir + power cable
8	MA+		Grey (8)		Black (4)	White/Black from motor
7	MA-		Orange (7)		Orange (3)	Orange from motor
6	MB+		White (6)		Red (2)	White/Red from motor
5	MB-		Yellow (5)		White (1)	Yellow from motor
4	DIR	Blue (4)	Blue (4)	Blue		Blue
3	SCK	Brown (3)	Brown (3)	White		Brown
2	24V	Red (2)	Red (2)	Red		Red
1	GND	Black (1)	Black (1)	Black + Shield Black		Black
Connector		AMP MTA-100 640440-4	AMP MTA-100 640440-8	AMP MTA-100 640440-4	AMP MTA-100 640440-4	AMP MTA-100 640440-8
Number of conductors		4	8	4 + shield	4+ shield to cable clamp	4
Conductor area		AWG22 0.35 mm <sup>2</sup>	AWG22 0.35 mm <sup>2</sup>	AWG22 0.35 mm <sup>2</sup>	AWG22 0.35 mm <sup>2</sup>	AWG22 0.35mm <sup>2</sup>
Cable diameter		-	-	4.5mm	5mm	
Length		1 m	1 m	5m	5m	2m

### Connector:

We recommend an AMP connector type MTA-100 640440 because the AWG22 cable fits that connector. Other

connector types with 2.54 mm spacing can also be used. Remember to use a cable and terminal in the connector

that can withstand currents up to 4 Amp.



**\* Warning.**

If these cables are used for "SMD73-x-xxxx-Fxx" (drivers with input set-up for 5V) be sure that the ground wire (black) is not longer than 10-20 cm from the signal source producing the clock and direction signal. If a longer ground wire

is used it can introduce unintended noise at the clock signal which will make the motor stall or be unstable. In general it is recommended to split the ground wire in 2 wires as close to the driver as possible. One ground for

the power supply and one for the clock and direction signal. An idea could be to use the mounting holes as supply ground since they are internally grounded. All 4 mounting holes are grounded together.

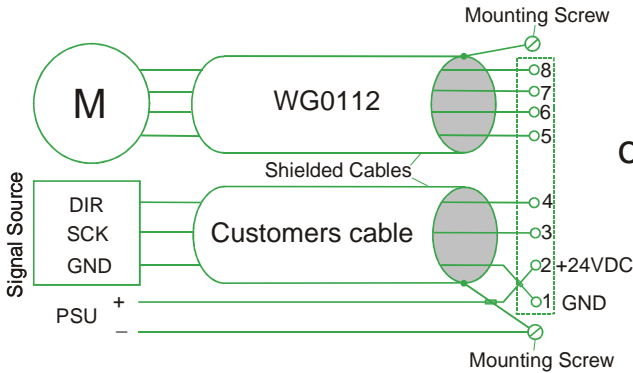

OR

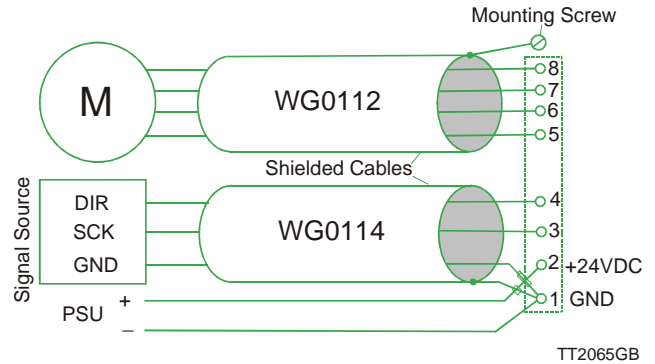

TT2065GB

**Cables**

A variety of cables are available for connecting the SMD73 driver to other equipment.

JVL Order no.	Description	Length (m)	Conductor area (mm <sup>2</sup> )	Number of conductors
WG0104	4 pole con	1	0.5	4
WG0108	8 pole con.	1	0.5	8
WG0112	Motor cable with shield	5	0.5	4
WG0114	Clk/Dir cable with shield	5	0.5	4

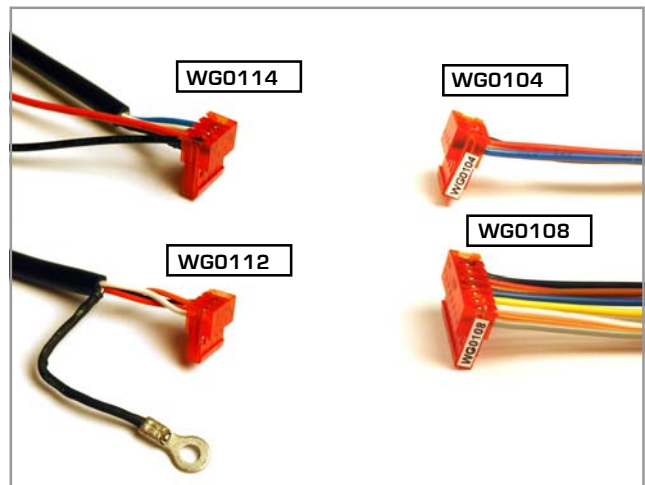

**Measuring Points TP1 and TP2**

Wires can be connected to the measuring points TP1 and TP2 for other purposes.

1: "Power", green LED on SMD73, is supplied from +24VDC via a resistor of 4,7 kOhm. The cathode of the LED is connected to ground. The measuring point TP2 is the anode of the LED. When the LED is lit, there is 1 volt on TP2. If the LED is removed, there will be +24VDC on TP1.

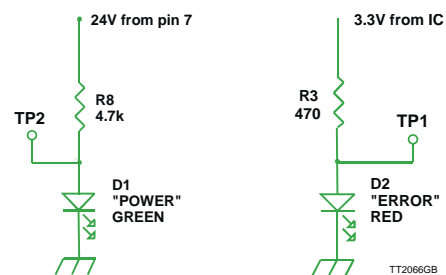

TT2066GB

2: "Error", red LED on SMD73, is supplied from an IC (EPLD) output of 3.3VDC via a 470 ohm resistor. The cathode of the LED is connected to ground. The measuring point TP1 is the anode of the LED. When the LED is lit, there is approximately 1 Volt on TP1. If the LED is removed, there will be +3.3VDC on TP1.

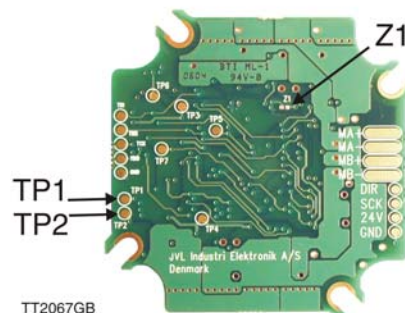

TT2067GB



### SMD73 driver with internal oscillator. (Only available with SMD73-4 with 1/4-step resolution)

The H version provides the possibility for an internal oscillator so that the motor will run simply by activation of input1 (Step-clock). The direction of rotation can be changed by activating input 2 (Direction). 24V PNP/NPN and 5 V inputs as well as different currents are possible. The step resolution is fixed at 800 ministeps/revolution.

Changing the value of resistor R4 will change the speed. No acceleration or deceleration is introduced which means that the motor speed will immediately go up to the chosen value. If too high a speed is chosen, the motor will not start since the load inertia is too high. The table below shows how to change the speed. Please interpolate between the values if other speeds are required.

Please note that the PWM frequency of the motor voltage will also change. If a motor with a low inductance is used, the PWM frequency can be audible. The speed tolerance is +/- 10 %, mostly because of initial tolerances and temperature changes.

R4	Speed (H1) SMD73-4-xyzH1	Speed (H2) SMD73-4-xyzH2	Speed (H3) SMD73-4-xyzH3	PWM frequency
470 Ohm (default)	86.4 RPM	172.8 RPM	345.6 RPM	17.6 kHz
560 Ohm	78.2 RPM	156.4 RPM	312.8 RPM	15.92 kHz
680 Ohm	67.2 RPM	134.4 RPM	268.8 RPM	13.68 kHz
820 Ohm	61.2 RPM	138.0 RPM	244.8 RPM	12.02 kHz
1K0 Ohm	53.5 RPM	107.0 RPM	214.0 RPM	10.90 kHz
1K50hm	44.0 RPM	88.0 RPM	176.0 RPM	8.96 kHz
2K2 Ohm	30.7 RPM	61.4 RPM	122.8 RPM	6.25 kHz
2K7 Ohm	22.4 RPM	44.8 RPM	89.6 RPM	4.56 kHz

#### WARNING !

Do not change the value of R4 to a value outside the range given above, since this can damage the driver.

#### Ordering example:

1.25 amp/phase motor. Speed 236 RPM and 24V PNP. Select the H3 version and change R4 resistor from 470 ohm to 820 Ohm. PWM frequency will be about 12 kHz.

Order no. SMD73-4-1250E03H3.  
For orders over 100 units, JVL can mount the resistor. Order no. SMD73-4-1250E03H3820

#### Motor for Driver SMD73

A special version of the high torque step motor MST001A is available as type MST001A-73. This model is prepared for rear mounting of the SMD73 driver and can be delivered from stock. It is provided with fixtures for the driver and cabling with driver connector, and thus offers an optimal solution for a complete integrated small step motor. The combination includes 1000mm lead wires for supply, step CLK and direction.

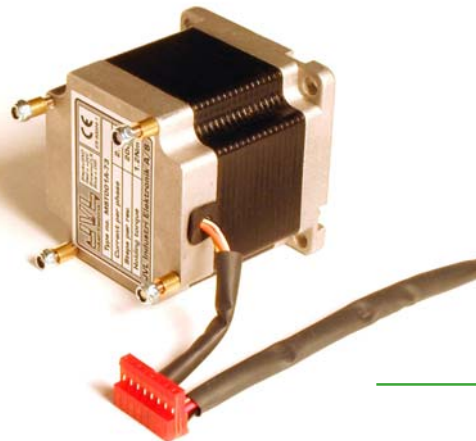

#### Indexer for Driver SMD73

An Indexer SMI70 with the same dimensions as SMD73 is also available. It has 6 I/O which can be configured to 6 inputs 5-30VDC, 6 PNP outputs 5-30VDC/0.5A or 6 analog inputs 0-5V or a combination. See also datasheet for SMI70



JVL Industri Elektronik A/S  
Blokken 42  
DK-3460 Birkerød, Denmark  
Tel: +45 4582 4440  
Fax: +45 4582 5550  
E-mail: jvl@jvl.dk www.jvl.dk

