

COOLING SYSTEMS

TECHNICAL MATERIAL

Overview and characteristics of fan motors

Overview

Fan motors are widely used to conduct forced air-cooling on heat-producing electronics mounted in high density, to radiate heat, and to extend the life of electronics systems. Since Sanyo Denki created Japan's first AC fan motor, SAN ACE, in 1965, the company has been responding quickly to customers' needs on the basis of that achievement, and has been providing a long line-up of products. Sanyo Denki will continue to conduct further research and development for more quiet, smaller, thinner, and better energy-saving products.

Characteristics

Fan motors fall into two categories: AC and DC.

AC fans

Sanyo Denki succeeded in the mass-production of AC fans in 1965. Sanyo Denki was the first Japanese manufacturer to have succeeded at this.

- High performance
- High reliability
- Safety

DC fans

Sanyo Denki succeeded in the mass-production of DC fans in 1982.

- High performance
- Low power consumption
- Low vibration
- Low leakage flux
- High reliability

These days, Sanyo Denki has a wider variety of products (Long Life Fan, CPU cooling fans "SAN ACE MC", and Splash Proof Fan) to meet all customer needs.

Guideline in selecting a fan motor

How to select an appropriate fan motor

The following example is a guideline on to how to select an appropriate fan motor for cooling heat-producing equipment by forced air-cooling.

1. Determining equipment specifications and conditions

Determine the temperature rise inside the equipment and obtain the total heat generated inside the equipment on the basis of its inputs and outputs.

Example

V : Total heat generated by the equipment (W) =100 (W)
 ΔT : Inside temperature rise (K) =15 (K)

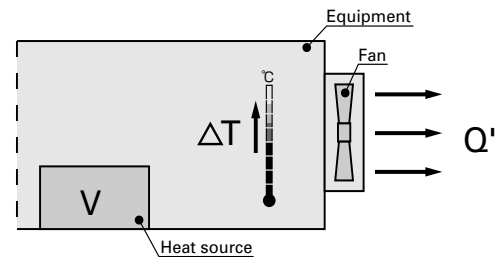

2. Calculating the Motion Air flow Required for Cooling

After the equipment specifications and conditions have been determined, calculate motion air flow required to satisfy the conditions. (Note that the formula shown below only applies when the heat radiation is performed only by cooling air from the fan motor.)

Example

Q': Motion air flow (m³/min.)

$$Q' = \frac{V}{20\Delta T} = \frac{100 \text{ (W)}}{20 \times 15 \text{ (K)}} \doteq 0.33 \text{ (m}^3/\text{min)}$$

3. Selecting the Fan Motor

After the motion air flow has been calculated, select an appropriate fan motor based on the value.

The motion air flow when the fan motor is actually incorporated into the equipment can be obtained using the air flow-static pressure characteristics graph and equipment pressure loss.

Select a fan motor when operating air flow is determined. The operating air flow, when the fan motor is actually mounted in the unit, can be obtained from the air flow-static pressure characteristic graph and the pressure loss of the unit. However, the pressure loss cannot be measured without a measuring instrument, so usually the fan with 1.5 to 2 times larger capacity than the operating air flow (operating air flow is one-third to two-thirds of maximum air flow) should be selected.

Example

Q: Maximum air flow (m³/min.)

$$Q' = Q \times 2/3$$

$$Q = Q' \times 3/2 = 0.33 \times 3/2 \doteq 0.5 \text{ (m}^3/\text{min)}$$

Next, select a fan motor having an air flow of 0.5 (m³/min.) or more and a size appropriate for the space inside the equipment.

For example, a fan of 60mm square, 25mm thickness and 12V rating is 109R0612H402 (maximum air flow = 0.53m³/min.).

4. Confirming the Selected Fan Motor

Calculate the temperature rise inside the equipment when equipment having 100 (W) of total heat generation is forcefully cooled down with a 109R0612H402 fan motor.

Example

$$Q' = Q \times 2/3 = 0.53 \times 2/3 \doteq 0.353 \text{ (m}^3/\text{min)}$$

$$\Delta T = V/20Q' = 100 \text{ (W)} / 20 \times 0.353 \text{ (m}^3/\text{min)} \doteq 14.2 \text{ (K)}$$

From the above, the temperature rise inside is calculated as 14.2 (K).

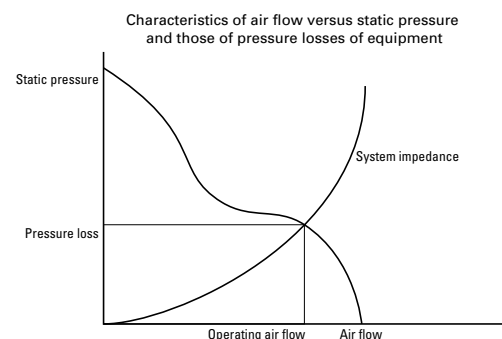

Since the value obtained from the above equation is only a typical one, final fan selection should be based on an actual installation test.

Characteristics calculation procedure and description

Reliability and service life

A fan motor generally cools itself. The temperature rise of the motor is relatively low and the temperature rise of the grease in the bearings is also low, so fan motors are expected to last longer than general motors. Since the service life of bearings is a theoretical value that applies when they are ideally lubricated, the service life of lubricating oil can be said to be that of the fan. The service life of an AC fan used at an ambient temperature of 60°C is 25,000 hours. The BLDC fan consumes little power and its bearings are subjected to little heatup, thus its service life is 40,000 hours at an ambient temperature of 60°C. Sanyo Denki has provided a line-up of Long Life Fans that last

200,000 hours (SAN ACE 120L) and 100,000 hours (SAN ACE 80L, 92L, 80W, 92W, 120W, 140L, and 140W) at an ambient temperature of 60°C with an even more enhanced structure and material. The table below indicates the relationship between ambient temperature and service life estimated on the basis of service life tests and other tests conducted by Sanyo Denki. (The survival rate is 90%.) An accelerated service life test is conducted on the basis of the concept that the service life doubles as the ambient temperature rises by about 15°C (within the operating temperature range of lubricating oil).

Life expectancy of DC fan

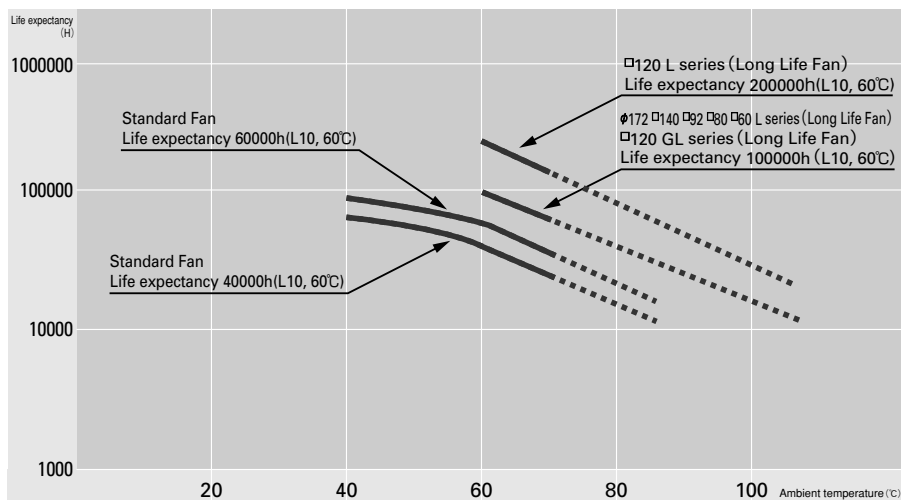

Rated voltage, continuous operation, free air, survival rate of 90%

Life expectancy of AC fan

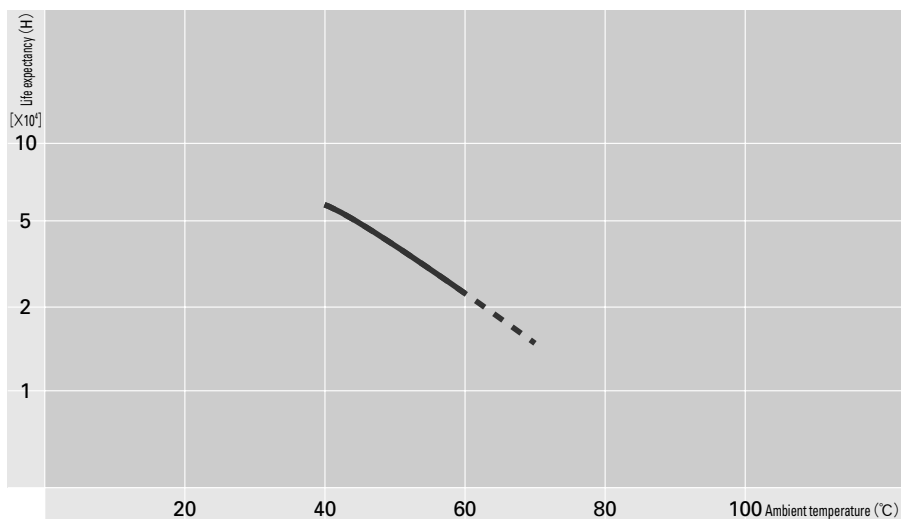

Rated voltage, continuous operation, free air, survival rate of 90%

Noise characteristics

Noise measurements are central values as measured at a point 1m from the suction surface of a fan suspended in an anechoic room (as per JIS B 8330).

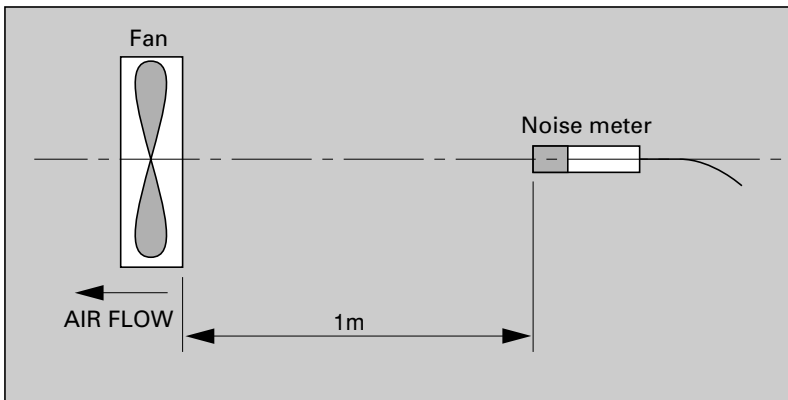

General specifications

Insulation resistance

10M Ω or more with a 500 VDC megger (between the lead conductor and frame).

Preserving temperature range

-30°C to +70°C (no dew condensation).

Characteristics calculation procedure and description

Measuring air flow and static pressure

Air flow and static pressure are very difficult to measure. In fact, the performance curve may vary greatly according to the type of measuring instrument.

The commonly-used type of measuring instrument is a wind tunnel measuring device based on a Pitot tube. Sanyo Denki uses a very precise method that has a double chamber equipped with many nozzles.

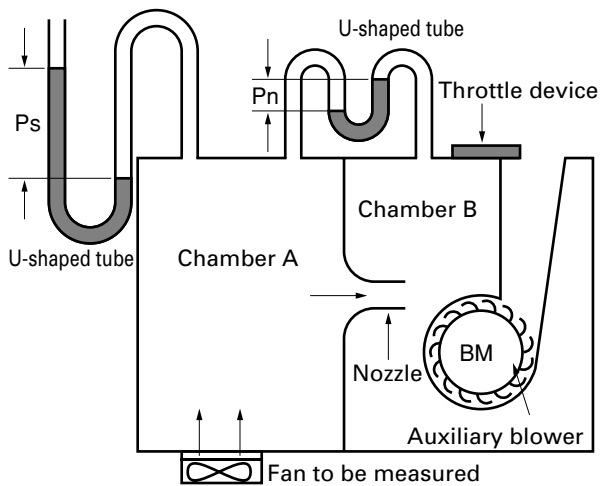

Double chamber measuring device

$$Q = 60A\bar{v} \text{ (A)}$$

where

Q = air flow (m³/min)

A = cross sectional area of nozzle = $\frac{\pi}{4} D^2$ (m²)

D = nozzle diameter

\bar{v} = average flow velocity of nozzle = $\sqrt{2g \frac{P_n}{\gamma}}$ (m/sec)

γ : Air specific weight (kg/m³)

($\gamma = 1.2 \text{ kg/m}^3$ at 20°C, 1 atmospheric pressure)

g = acceleration of gravity = 9.8 (m/sec²)

P_n = differential pressure (mm H₂O)

P_s = static pressure (mm H₂O)

The measuring device based on a double chamber (left-hand figure) is a method of determining the pressure difference (static P_s) inside the chamber between the air flow through the nozzle and the atmospheric pressure. The device measures the pressure difference (differential pressure P_n) before and after the nozzle.

Conversion Table

Static pressure

1mm H₂O = 0.0394inch H₂O

1mm H₂O = 9.8Pa (Pascal)

1inch H₂O = 25.4mm H₂O

1Pa = 0.102mm H₂O

1inch H₂O = 249Pa

Air flow

1m³/min = 35.31ft³/min (CFM)

1CFM = 0.0283m³/min

1m³/min = 16.67ℓ/sec

1CFM = 0.472ℓ/sec

1ℓ/sec = 0.06m³/min

Operating precautions

Operating precautions

Storage temperature

There is no performance-related problem when the equipment is operated between -30°C and $+70^{\circ}\text{C}$. Any dew condensed due to a rapid temperature change may affect lubrication performance and insulation. Therefore, use a desiccant or other means to prevent dew condensation during storage.

Recommended screw torque installation

The frame of the fan motor is made of an aluminum die-casting or plastic. The recommended screw torques for fan installation are as follows:

Recommended screw torques

AC fan motor : $0.44\text{N}\cdot\text{m}$ (4.5kgf $\cdot\text{cm}$) or less (with M3 screws)

AC fan motor : $0.78\text{N}\cdot\text{m}$ (8kgf $\cdot\text{cm}$) or less (with M4 screws)
(San Ace172/San Ace160)

DC fan motor : $0.44\text{N}\cdot\text{m}$ (4.5kgf $\cdot\text{cm}$) or less (with M3 screws)
(Applies to fan motors of 52mm \times 52mm or smaller)

DC fan motor : $0.78\text{N}\cdot\text{m}$ (8kgf $\cdot\text{cm}$) or less (with M4 screws)
(Applies to fan motors of 60mm \times 60mm or bigger)

DC fan motor : $0.98\text{N}\cdot\text{m}$ (10kgf $\cdot\text{cm}$) or less (with M4 screws)
(San Ace200)

Comparison of ribbed and ribless structures (in the case of plastic frame BLDC fan)

The mounting base of Sanyo Denki's mold frame DC fans is either ribless or ribbed. Select the appropriate type according to your particular application. (Some models are available with a ribbed base only.)

*Use a fan motor with a rib structure when using a screw for piercing.

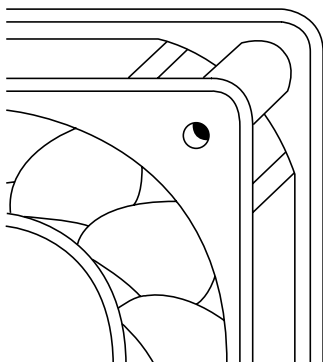

Ribbed

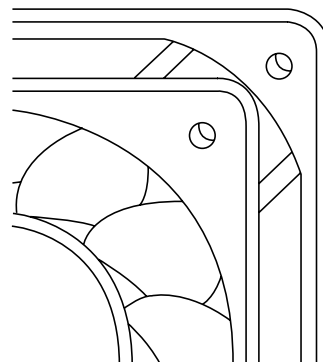

Ribless

Handling precautions

Sanyo Denki's fan motors incorporate precision bearings. Therefore, handle the motors with care in order not to shock the bearings.

Specifications for DC fan sensors

Pulse sensor (rotation signal output type)

Pulse sensors produce two-cycle rectangular waves per rotation of fan motor. These are best suited for detecting rotating speeds. Pulse sensors can be incorporated in all kinds of BLDC fan motors. (Typical standard model: 109R1212H1H01).

Output circuit

Open collector

Specifications

$V_{CE} = +30V$ max
 (For a 48V-rated fan motor: $V_{CE} = +60V$ max)
 $I_c = 10mA$ max [$V_{OL} = V_{CE} (SAT) = 0.4V$ or less]

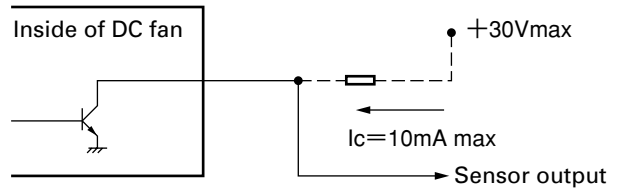

Output waveform (with load resistance connected and pulled up)

During a normal run

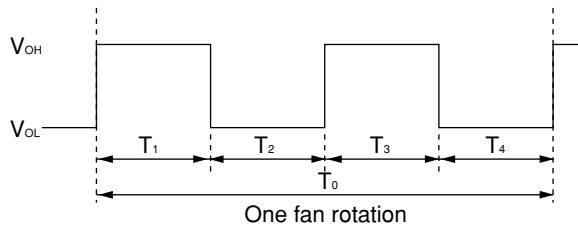

$$T_{1 \text{ to } 4} \doteq (1/4) T_0$$

$$T_{1 \text{ to } 4} \doteq (1/4) T_0 = 60/4N \text{ (sec)}$$

$$N = \text{Fan rotating speed (min}^{-1}\text{)}$$

* For the detailed specifications that apply when the impeller is locked, please contact Sanyo Denki.

Lock sensor (rotation/stop detection type)

Lock sensors produce fan motor status signals. These are best suited for detecting whether the fan motor is running or stopped (typical standard model: 109R1212H1D01).

* For details of the reverse sequence and specifications of lock sensor output signals, contact Sanyo Denki.

Output circuit

Open collector

Specifications

$V_{CE} = +27.6V$ max

For a 48V-rated fan motor $V_{CE} = +60V$ max.

$I_c = 5mA$ max [$V_{OL} = V_{CE} (SAT) = 0.6V$ or less]

For a 48V-rated fan motor: $V_{CE} (SAT) = 0.4V$ or less

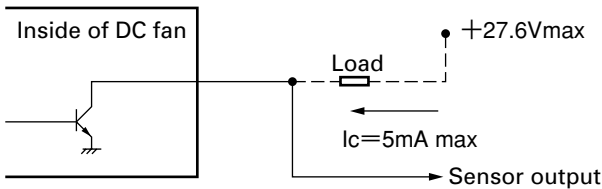

Output waveform

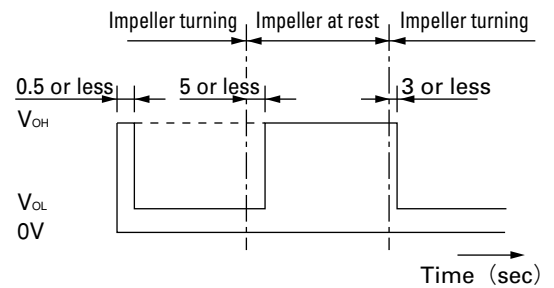

Note: The output is completely at V_{OL} for 0.5 seconds or less after power-up.

If you are using a thermally speed controlled fan or a two-speed fan, a different output waveform results.

Output circuit:

Open collector

Specifications:

$V_{CE} = 27.6V$ max

$I_c = 5mA$ max [$V_{CE} (SAT) = 0.5V$ max.]

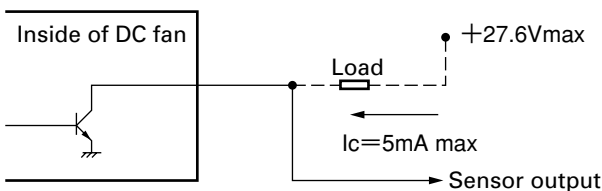

Output waveform

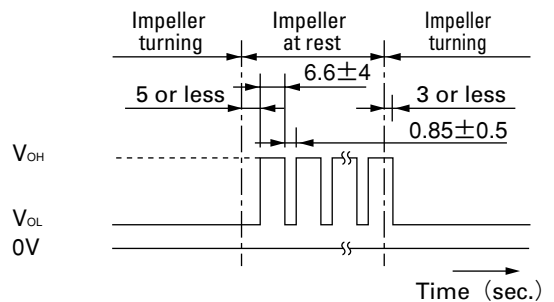

Note: The time required for output to completely become V_{OL} is 0.5 sec. max. after the power is turned on.

Specifications for DC fan sensors

Low-speed sensor (rotating speed detection type)

Low-speed sensors produce a signal when the rotating speed of the fan motor goes below the setting. These are best suited for detecting declines in the cooling capacity of fan motors.

To purchase a low-speed sensor, contact Sanyo Denki (typical standard model: 109R1212H1H01).

Output circuit

Open collector

Specifications

$V_{CE} = 27.6V$ max.

$I_c = 10mA$ max. [$V_{OL} = V_{CE} (SAT) = 0.5V$ or less]

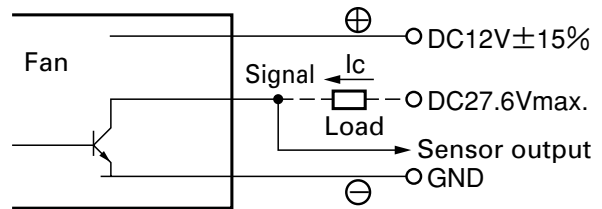

Sensor sequence

Example 1:

In normal status

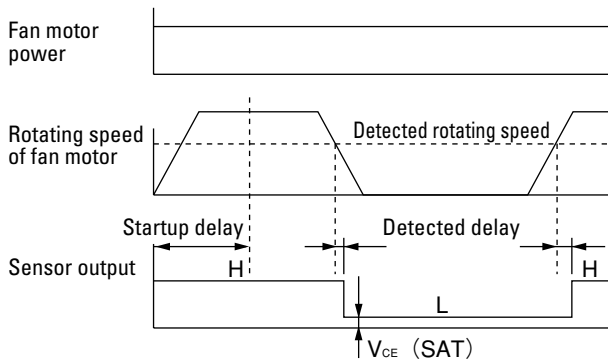

Example 2:

When the blades are locked when the fan motor is turned on and released after the start-up delay time.

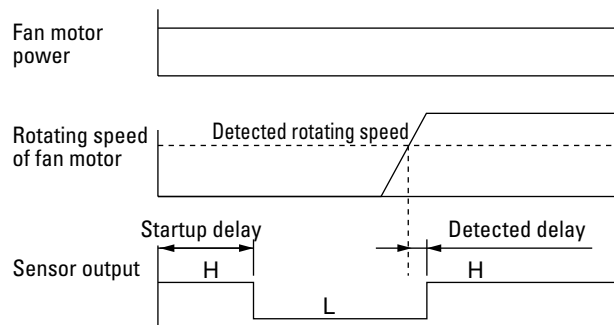

* Contact us for output signal reverse sequence and details of specifications.

Specifications for AC fan sensors

Specifications of sensor circuits

System	Rotating speed detection, automatic reset, and rapid resistance change types		
Power supply	4 to 14 VDC	(At 5V, 2mA)	See Note 2.
Sensor circuit	I=100mAmax	PT=200mWmax (at 25°C)	
Output performance	Vc=27.6Vmax		
		Standard speed	Low speed
Detected rotating speed		Within 1,700min ⁻¹ ±10%	Within 850min ⁻¹ ±10%
Response speed	Startup delay	18sec	36sec
	Detection delay	1sec	2sec
Insulation resistance	10 MΩ or more with a 500 VDC megger		
Dielectric strength	50/60 Hz, 1,000 VAC, 1 minute; see Note 1		
Ambient conditions	Temperature: -10 to +70°C, humidity: 90%RH or less (at 40°C)		

Note 1: Between one end consisting of sensor circuit leads (brown, yellow, and black) and the G terminal and power terminal of the fan.

Note 2: Keep the power fluctuations within the voltage setting ±20%.

Sensor sequence

Example 1: When the AC power of the fan motor and the power supply of the sensor circuit are turned on at the same time

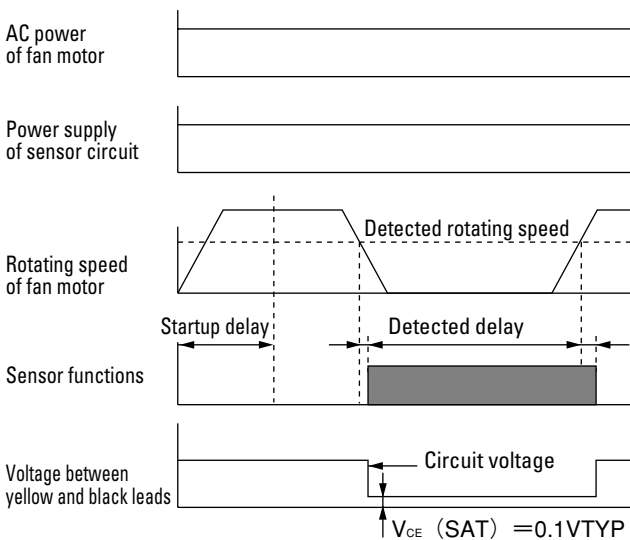

Example 2: When the AC power of the fan motor is turned on first, then the sensor circuit is powered on

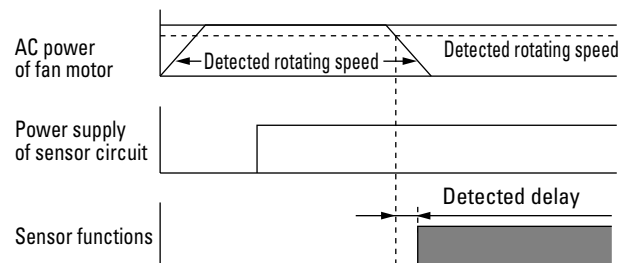

Example 3: When the sensor circuit is first powered on, then the AC power of the fan motor is turned on

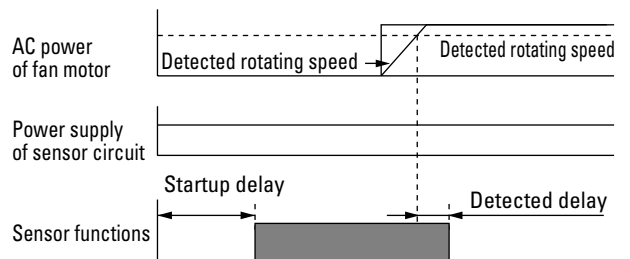

Sensor Output Circuit

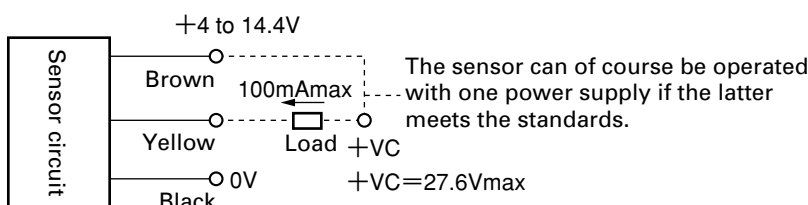

Notice Products listed on this catalog fall into the category of the cargoes specified in the Export Trade Control Ordinance (Attached Table1, Item 16). For the export of the above products, exporters are requested to implement export registration to the competent authorities, together with the study about "Information Requirements and Objective Requirements" under the Japanese equivalent of catchall controls

SANYO DENKI

1-15-1, Kita-otsuka, Toshima-ku, Tokyo 170-8451, Japan. PHONE : +81 3 3917 5151 Home Page:<http://www.sanyodenki.co.jp>